

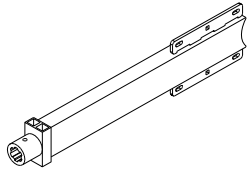

**Rent the System you need**

**Basic System** with inventory control cabinet – **Config 28** part #40-50-1002

The basic system contains components for moving 28 linear feet (4' centers) of double sided gondola shelving. As listed:



**SPLINED LIFT ARM**  
QTY 16

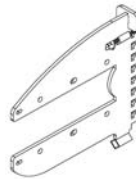

**STANDARD LIFT FINGER**  
QTY 16

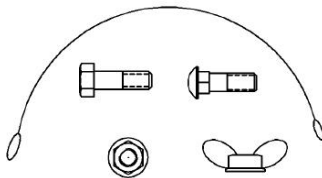

**HARDWARE KIT**  
QTY 1

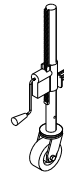

**CASTOR JACK ASSLY**  
QTY 16

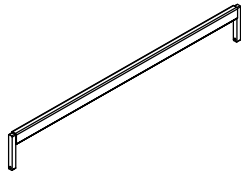

**CONNECTING BEAM-4'**  
QTY 14



**INVENTORY CONTROL CABINET**  
QTY 1

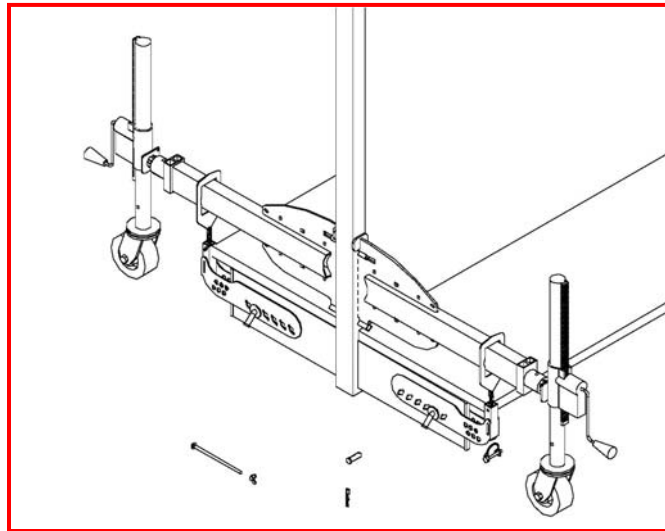

**RENT**

**Cat # 40-50-1002-Link 4 Gondola moving system config28: Call for price**

Rental rate for this configuration:

First monthly rental charge	
For each additional week thereafter	
Outright purchase price	

*A portion of your rental cost can be applied toward the purchase of your unit.*

*\*Your gondola may require additional gear.*

*\*\*Freight charges will be applied in addition to the rental costs.*

Form 2011